



**Smart<sup>®</sup>**  
Installation Tool



## SM-FT-2000 Banding Tool Instructions

### READ ALL INSTRUCTIONS BEFORE OPERATING HCL BANDING TOOLS

#### SM-FT-2000-13

Suitable for:  
Smart<sup>®</sup> Band 7mm (1/4")  
Smart<sup>®</sup> Band 10mm (3/8")

#### SM-FT-2000-19

Suitable for:  
Smart<sup>®</sup> Band 19mm (3/4")  
Smart<sup>®</sup> Tie 20mm (3/4")

#### SM-FT-2000-32

Suitable for:  
Smart<sup>®</sup> Band 32mm (1 1/4")  
Smart<sup>®</sup> Tie 32mm (1 1/4")

Incorporating both tightening and cutting mechanisms, the tool is fully corrosion resistant, lightweight, ergonomic and easy to use, ensuring that Smart<sup>®</sup> Band and Smart<sup>®</sup> Tie can be fitted quickly and efficiently.

## Operating Instructions



**STEP 1:** After hand tightening the band and buckle assembly, pass the tool over the excess and locate against the buckle. Squeeze handles together to tighten further.\*



**STEP 2:** Trim off excess band using cutting blade.\*



**SM-FT-2000-32**  
Do not operate the tool with the handles in the closed position.



**SM-FT-2000-32**  
Ensure that the extension handles are folded out and fixed in the operational position prior to use.

**\*Risk of pinch injury**

## Maintenance

Although fully corrosion resistant, clean and lubricate the tool regularly to maximise its working life, especially in salt water environments.

**IMPORTANT –  
DO NOT DESTROY**

It is the customer's responsibility to have all operators and service personnel read and understand this manual.

For additional copies please contact HCL or download from [www.hcl-clamping.co.uk](http://www.hcl-clamping.co.uk)



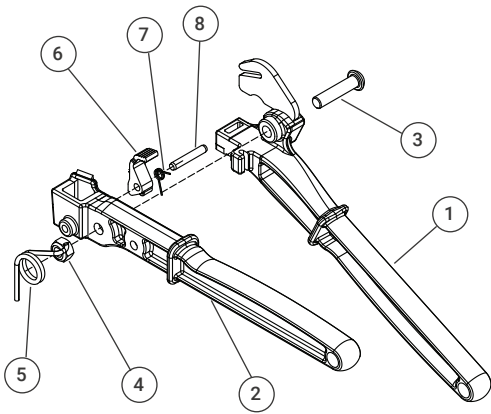

### SM-FT-2000-13

Item	Part Number	Title	Qty
1	ASM1116	Fixed Handle, Overmoulded Assembly, Generic	1
2	ASM1117	Moving Handle Assembly, Generic	1
3	BHS_M8X35_SS	Buttonhead Screw, SKT HD, M8x35LG, SS	1
4	NUT_NYLOC_HEX_M8_SS	Nut, Nyloc, Hexagon, M8, SS	1
5	PRT1453	Spring, Torsion, Smart® Band Fitting Tool	1
6	PRT1454	Pawl Gripping, 13mm	1
7	PRT1085	Spring, Torsion, Smart® Band Fitting Tool, 19mm	1
8	PRT1452	Pin, Ø5x30LG	1

#### IMPORTANT

If using the SM-FT-2000-13 tool in conjunction with 7mm Smart® Band, care should be taken not to over tighten the system. Excessive tightening may result in band failure.

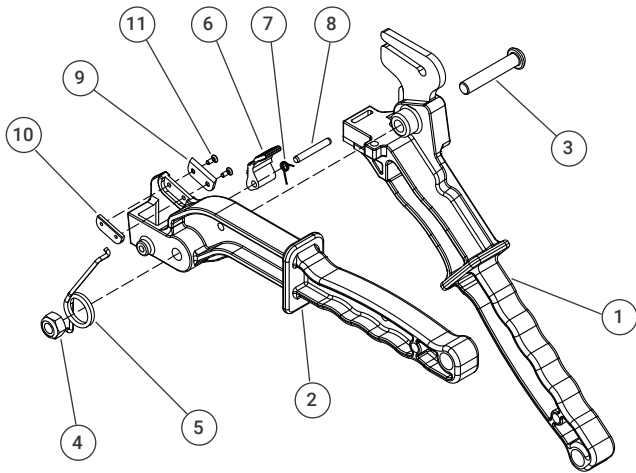

### SM-FT-2000-19

Item	Part Number	Title	Qty
1	ASM1030	Fixed Handle, Overmoulded Assembly, 19mm	1
2	ASM1032	Moving Handle Assembly, 19mm	1
3	BHS_M10X55_SS	Buttonhead Screw, SKT HD, M10x55LG, SS	1
4	NUT_NYLOC_HEX_M10_SS	Nut, Nyloc, Hexagon, M10, SS	1
5	PRT1075	Spring, Torsion, Smart® Band Fitting Tool	1
6	PRT1072	Pawl, 19mm	1
7	PRT1085	Spring, Torsion, Smart® Band Fitting Tool, 19mm	1
8	PRT1074	Pin, Ø5x36LG	1
9	PRT1070	Blade, Cutting	1
10	PRT1506	Blade, Clamp Plate	1
11	CSK_M3X8_SS	Countersunk Screw, SKT HD, M3x8LG, SS	2

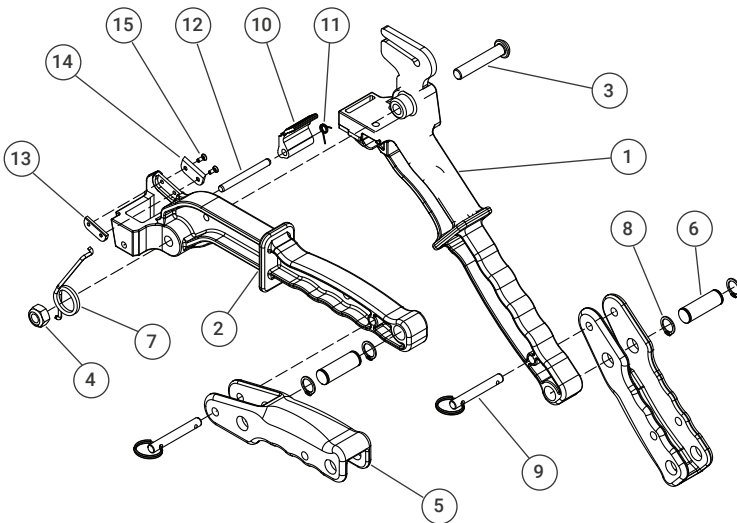

### SM-FT-2000-32

Item	Part Number	Title	Qty
1	ASM1084	Fixed Handle, Overmoulded Assembly, 32mm	1
2	ASM1085	Moving Handle, Assembly, 32mm	1
3	BHS_M10X55_SS	Buttonhead Screw, SKT HD, M10x55LG, SS	1
4	NUT_NYLOC_HEX_M10_SS	Nut, Nyloc, Hexagon, M10, SS	1
5	PRT1344	Extension Handle	2
6	PRT1354	Pivot Pin	2
7	PRT1075	Spring, Torsion, Smart® Band Fitting Tool	1
8	CIR_EXT_014_SS	Circlip, External, Ø14, SS	4
9	PRT1356	Detent Pin, WDS-957-20840	2
10	PRT1347	Pawl, 32mm	1
11	PRT1368	Spring, Torsion, Smart® Band Fitting Tool, 19mm	1
12	PRT1348	Pin, Ø6x60LG	1
13	PRT1506	Blade, Clamp Plate	1
14	PRT1070	Blade, Cutting	1
15	CSK_M3X8_SS	Countersunk Screw, SKT HD, M3x8LG, SS	2

#### HCL – UK & Rest of the World

Tel: +44 (0)1761 417714  
 Fax: +44 (0)1761 417710  
 Email: sales@hcl-clamping.co.uk

#### HCL – North America

Tel: 281-717-1145  
 Fax: 281-717-1146  
 Email: sales@hcl-clamping.com

Visit [www.hclfasteners.com](http://www.hclfasteners.com) to view our complete range of products.

March 2021

